

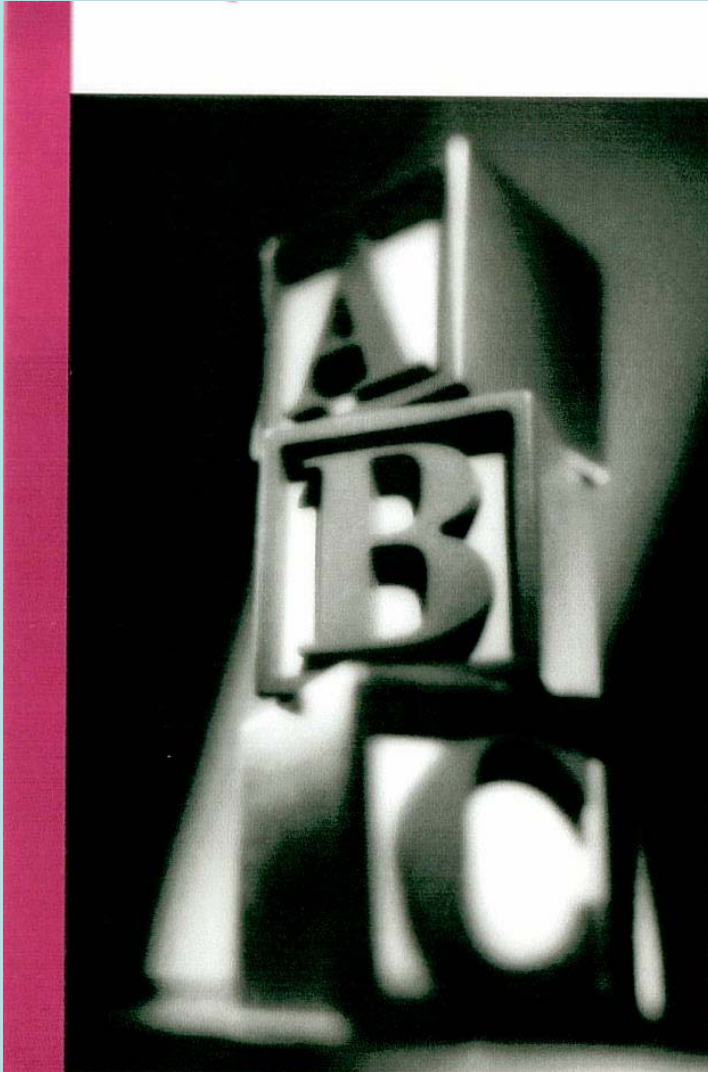

Deutsche Gesellschaft  
für Qualität e.V.

# ***Wie entstehen Normen? die Revision der ISO 9000-Familie***

***Regionalkreis Hamburg, 08. Mai 2007***



- gemeinnützig und unabhängig seit 1952
- Wir informieren und qualifizieren in Qualitäts- und Umweltmanagement / Arbeitssicherheit (ca. 20.000 Teilnehmer im Jahr)
- Wir arbeiten aktiv in der internationalen Normung mit
- Wir regen zur interdisziplinärer wissenschaftlicher Forschung an
- Wir informieren über neueste Erkenntnisse aus den Bereichen Qualität, Umwelt, Arbeitssicherheit in Form von Fachliteratur, Tagungen und Workshops
- Wir sind nach DIN EN ISO 9001 zertifiziert und als Personalzertifizierer nach DIN EN 17024 akkreditiert

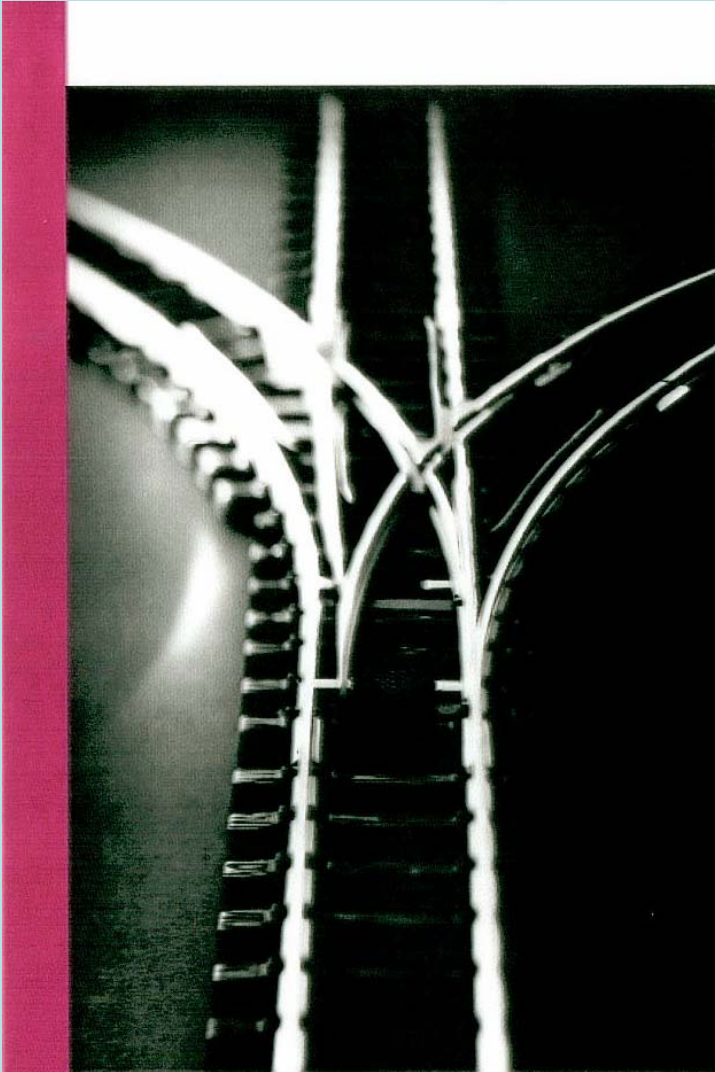

- Regionale Präsenz:
  - über 60 Regionalkreise bundesweit
  - vier Landesgeschäftsstellen(500 Veranstaltungen, 13.000 Teilnehmer)
- Gemeinschaftsarbeit:  
Fachleute aus allen Wirtschaftszweigen engagieren sich in Arbeitsgruppen (über 70 Titel)
- Gründungs- und Vollmitglied der EOQ
  - international anerkannte Ausbildung (EOQ - Zertifikate)
- nationale Partnerorganisation der EFQM
- Ludwig-Erhard-Preis:  
... für Spitzenleistung im Wettbewerb

- Ihre Erwartung an die Systemnormung
- Was kann Normung leisten?
- Stand der Systemnormung
- Organisation der internationalen Normung
- Aufbau des TC 176
- Aufbau des deutschen Spiegelgremiums
- Welche Dokumente werden einer Revision unterzogen?

Leicht umsetzbar

verständlich

Vielseitig anwendbar

praxisnah

???

unterstützend

problembezogen

konsistent

kohärent

verfügbar

- **Prinzipien**

- **Geplante Vereinheitlichung von materiellen und nichtmateriellen Gegenständen zum Wohl der Gesellschaft, die durch die interessierten Kreise gemeinsam durchgeführt wird**
- **Normung darf nicht zu wirtschaftlichen Vorteilen für eine besondere Gruppe führen**
- **Sie soll die Rationalisierung und die Qualitätssicherung in allen Sektoren von Wirtschaft; Technik und Wissenschaft und Verwaltung fördern**

(nach DIN 820:94.04)

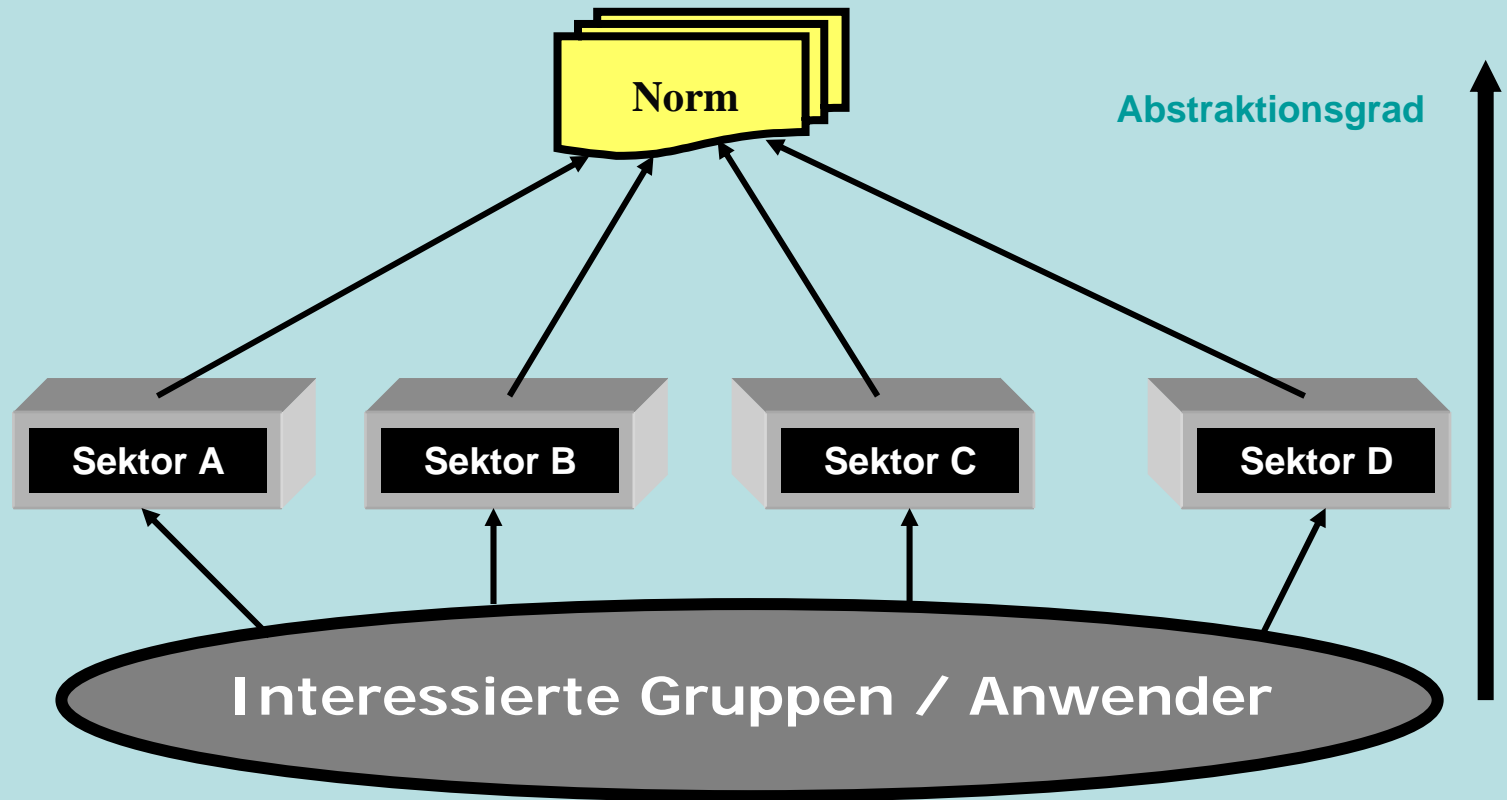

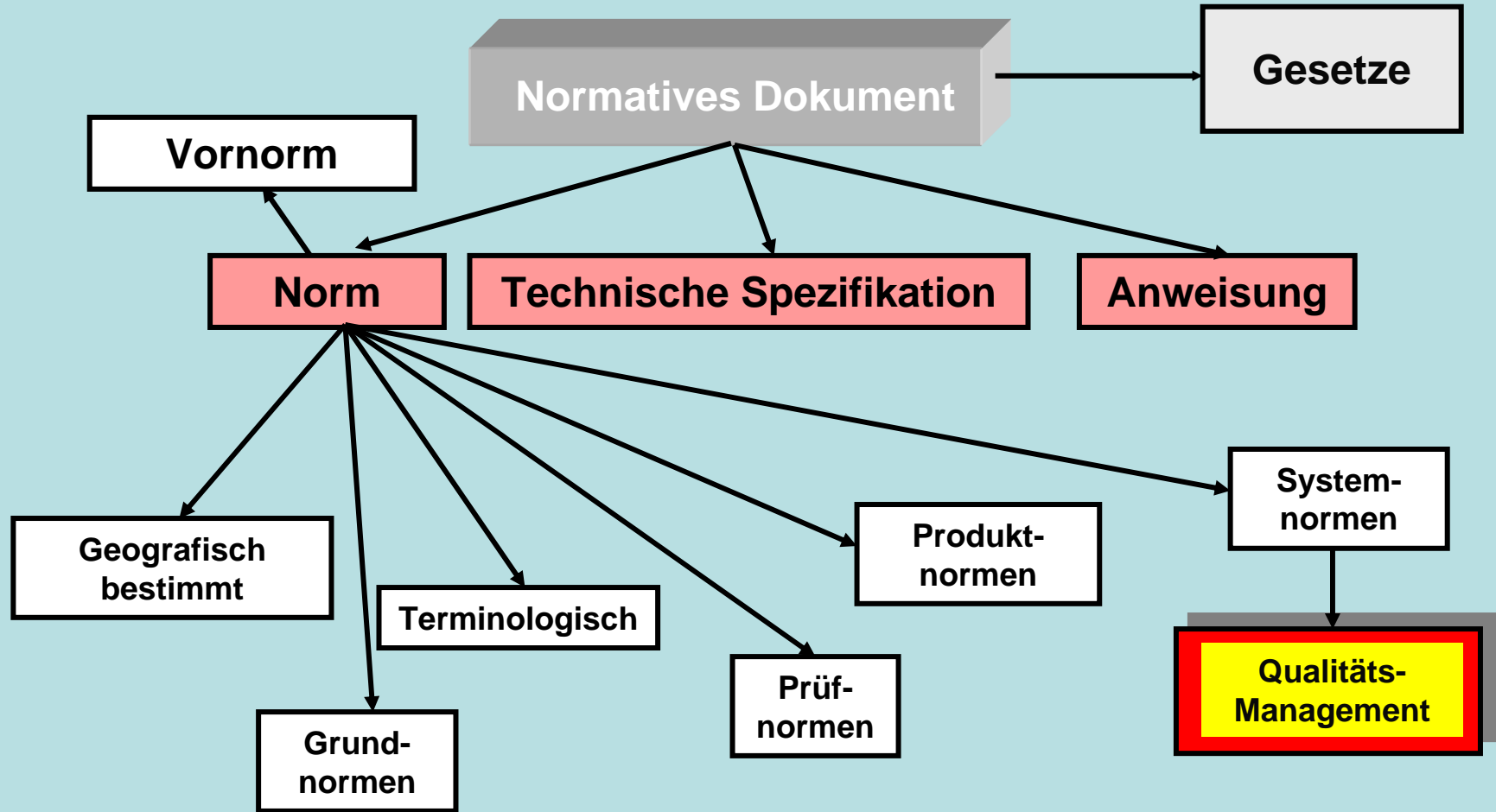

(DIN EN 45020:98.07)



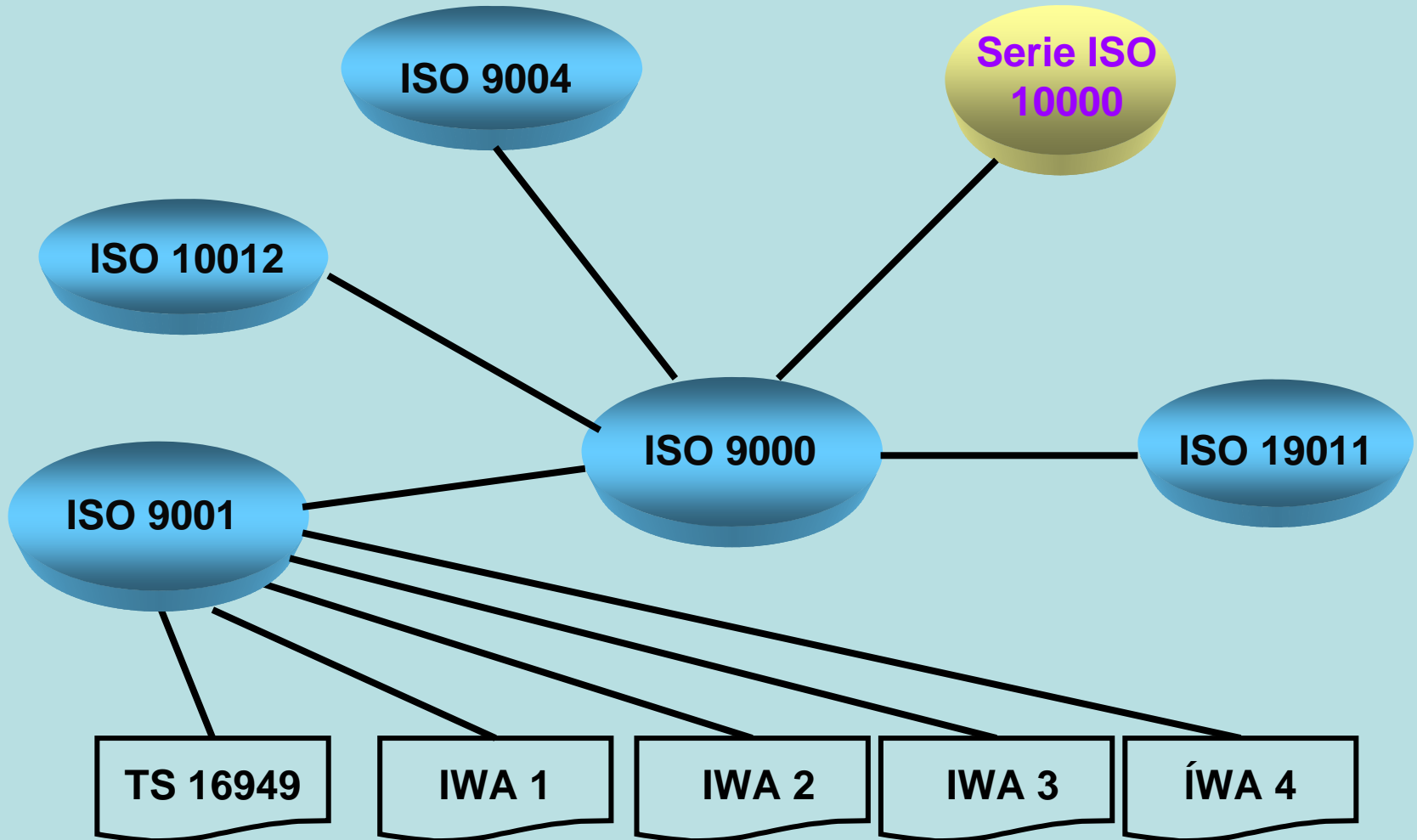

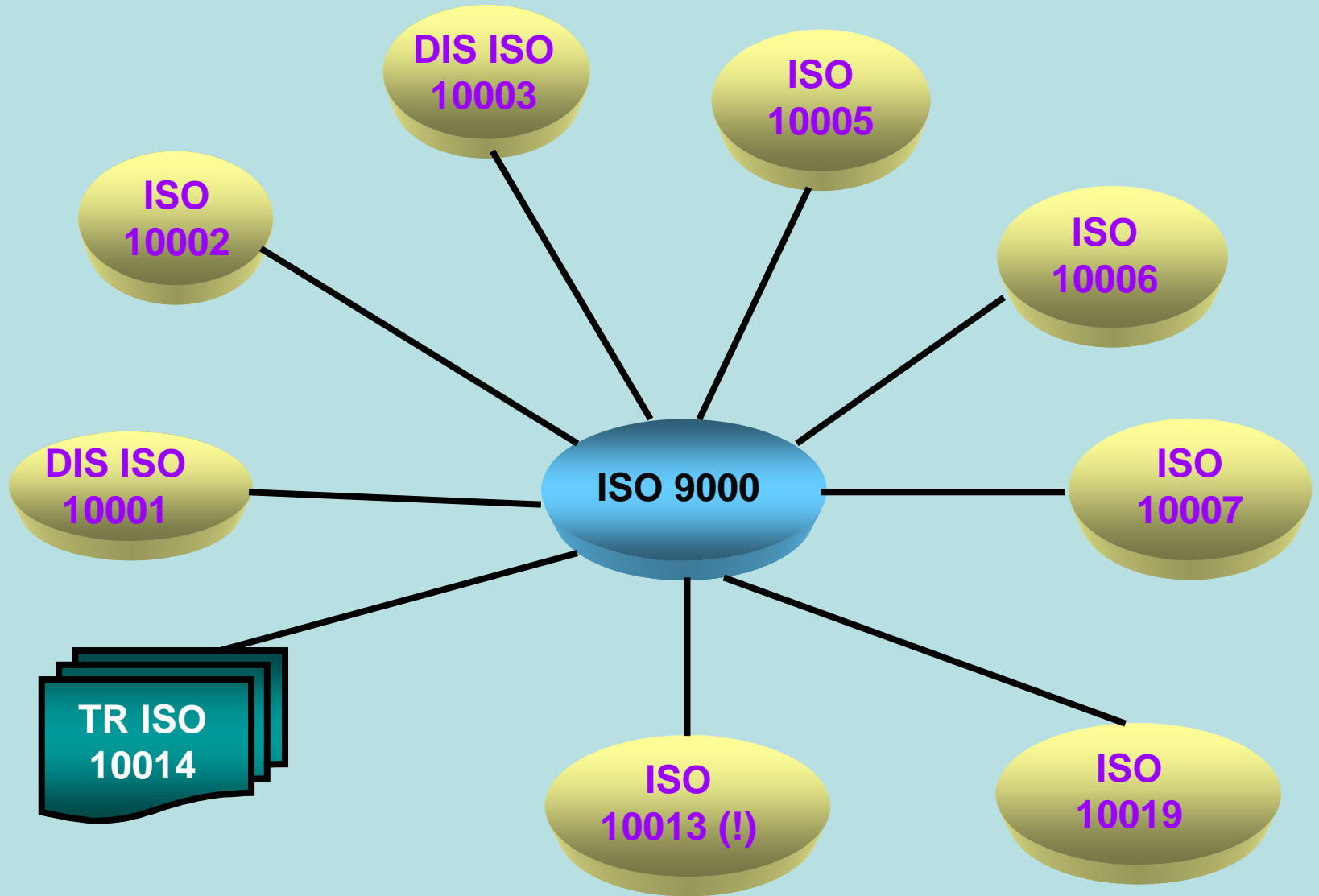

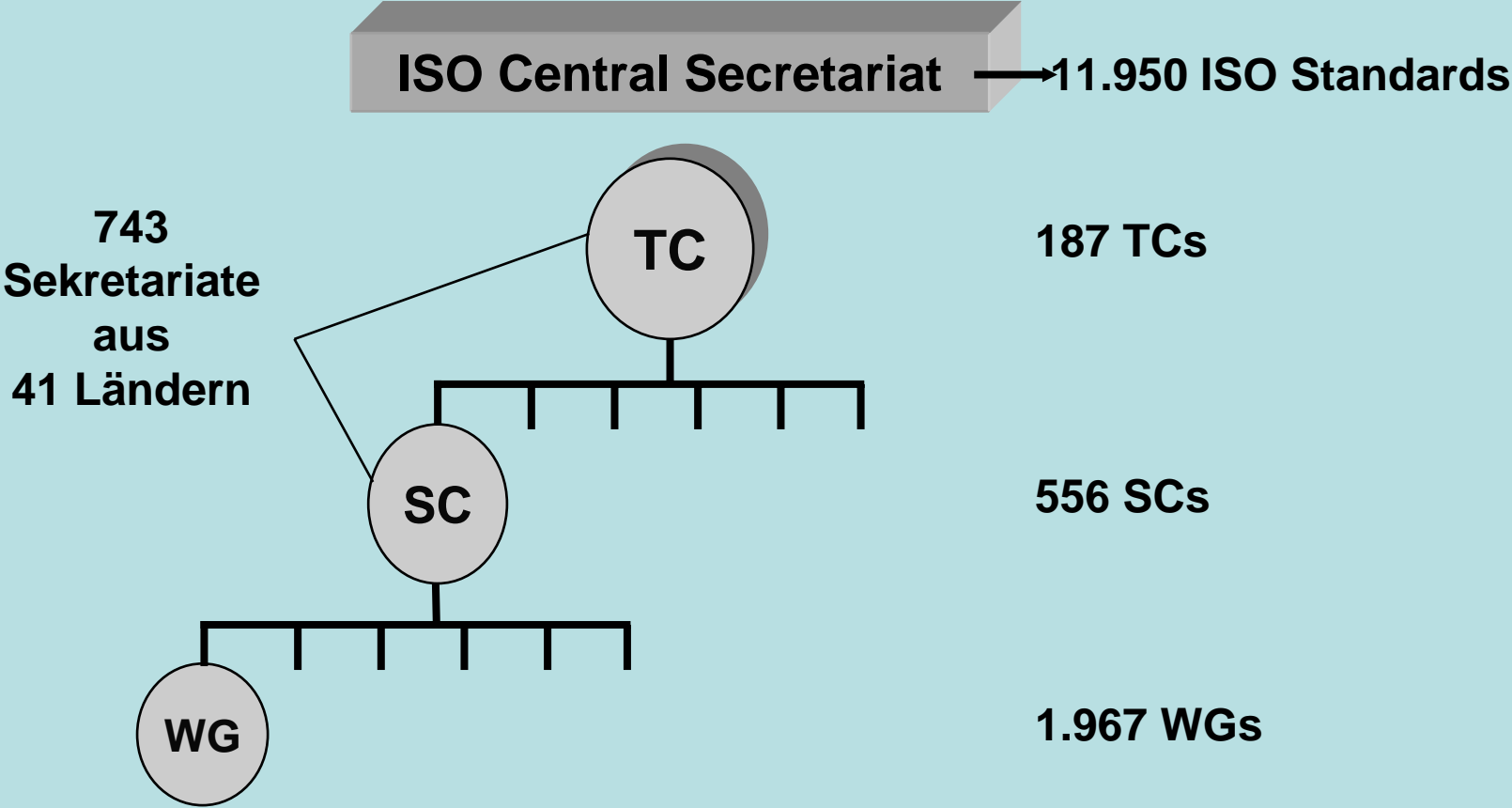

**~ 7.000 Aktive Projekte**

## Den Anwendungsbereich eines TC festlegen

*Es wird nur genormt, was sich in das Arbeitsgebiet eines TC einordnen lässt*

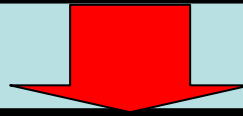

**Die interessierte nationale Normenorganisation legt einen Vorschlag vor, der den Titel, den Anwendungsbereich, das Ziel, eine Begründung und einen Projektplan enthält (NWIP).**

*nur, wenn diese Voraussetzungen erfüllt sind, beginnt ein Normenprojekt*

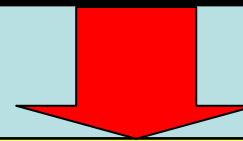

**Die Vollmitglieder (FM) stimmen über das Projekt ab und bekunden ihre Bereitschaft, Experten zu entsenden.**

*Nur die kontinuierliche Teilnahme bietet eine realistische Möglichkeit, das Endergebnis zu beeinflussen.*

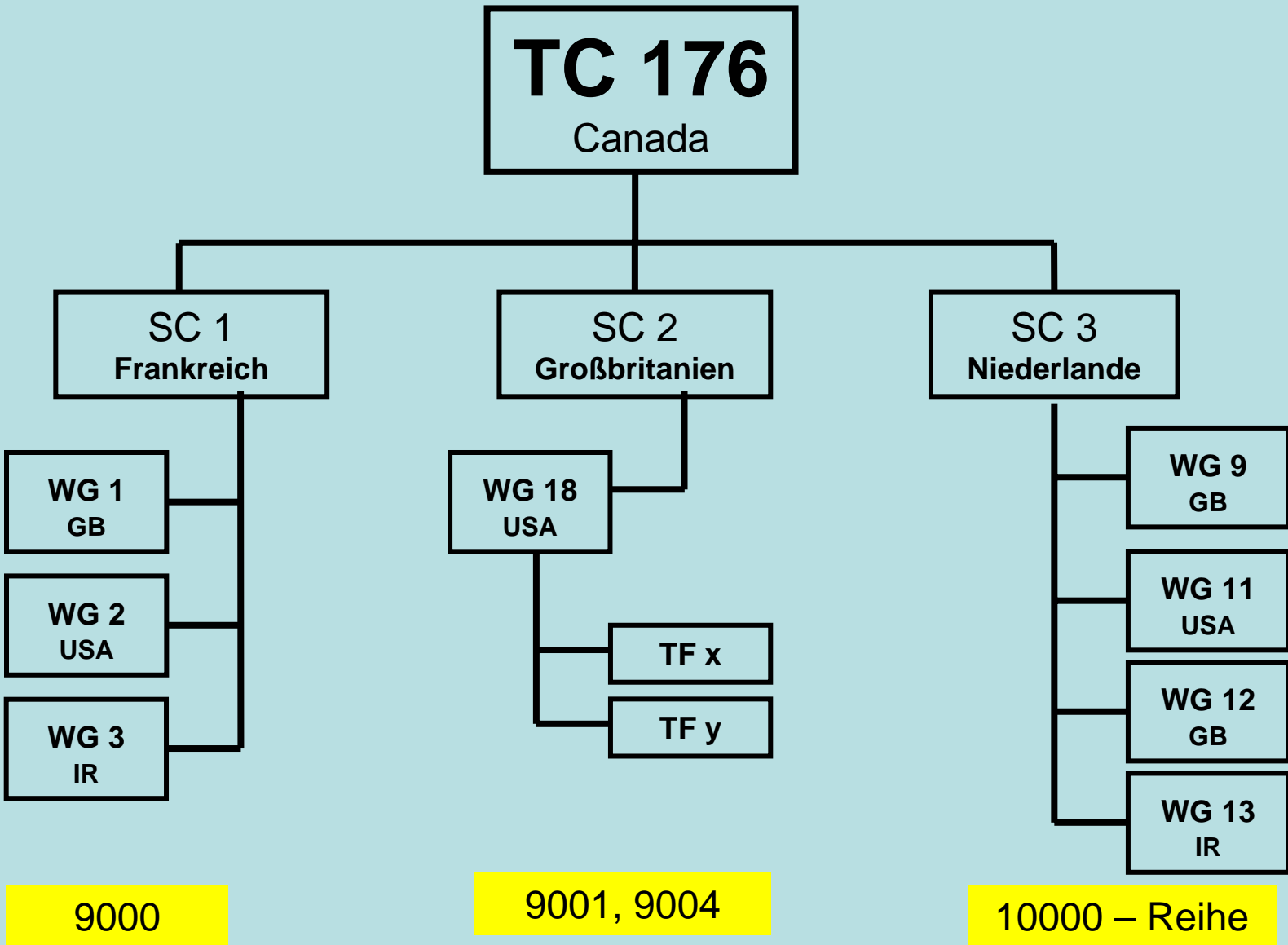

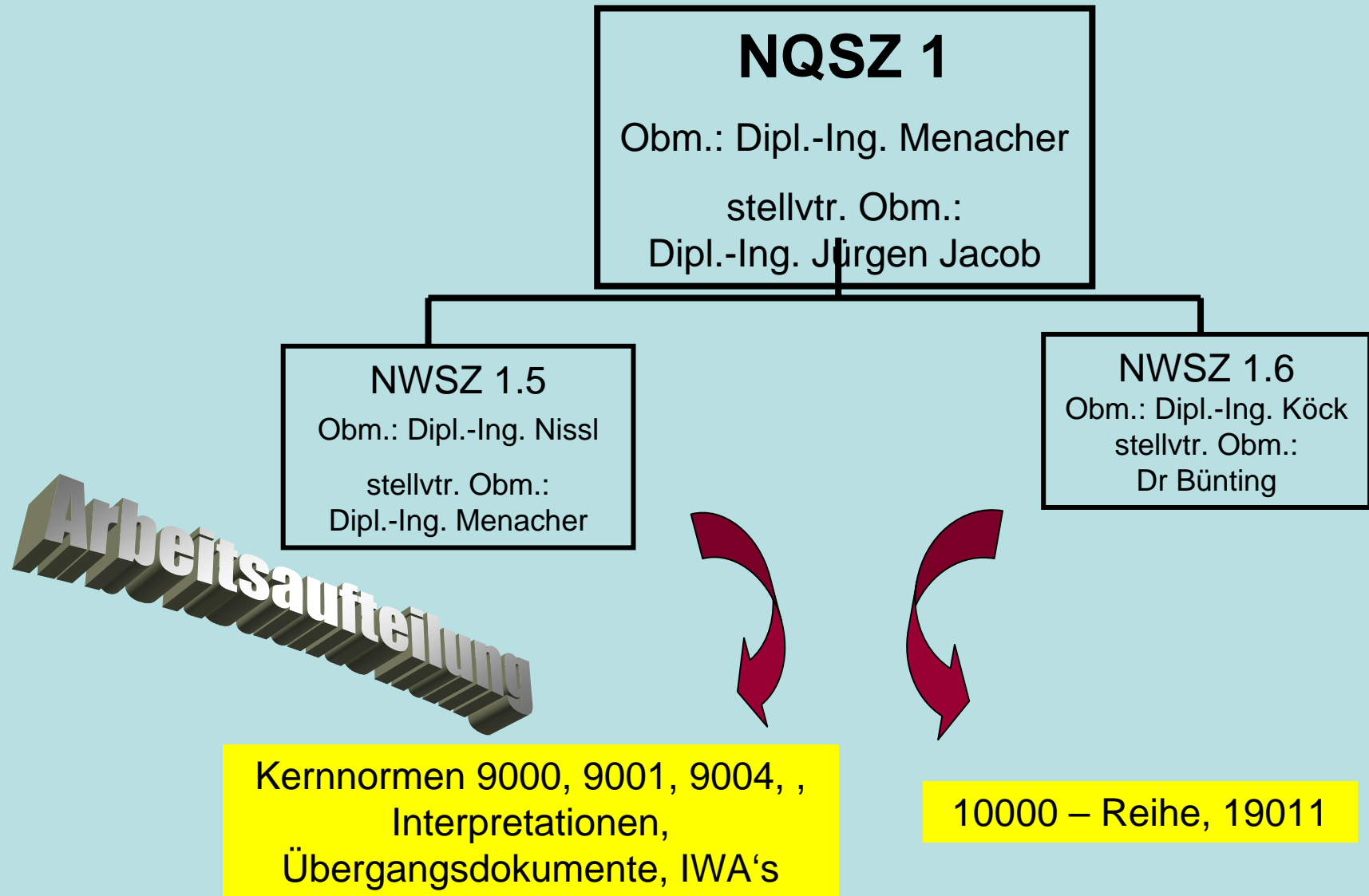

# The ISO 9000 Standards

---

What's New for 2009?

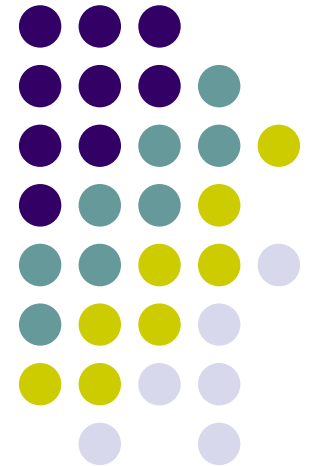

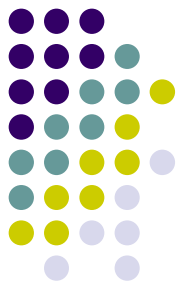

# Contents

- Rationale for updates
- The ISO Standards development process
- Scope of changes
  - ISO 9001
  - ISO 9004
- Timetable
- Contact details

# Rationale for updates.....



- ISO Review process:
  - Requires continual review to keep standards up to date. Must be initiated within 5 years of publication of the standard.
- User inputs:
  - Global user questionnaire/survey
  - Market Justification Study
  - Suggestions arising from the interpretation process.
  - Opportunities for increased compatibility with ISO 14001
- Current trends:
  - Keeping up with recent developments in management system practices.

# The ISO standards development process

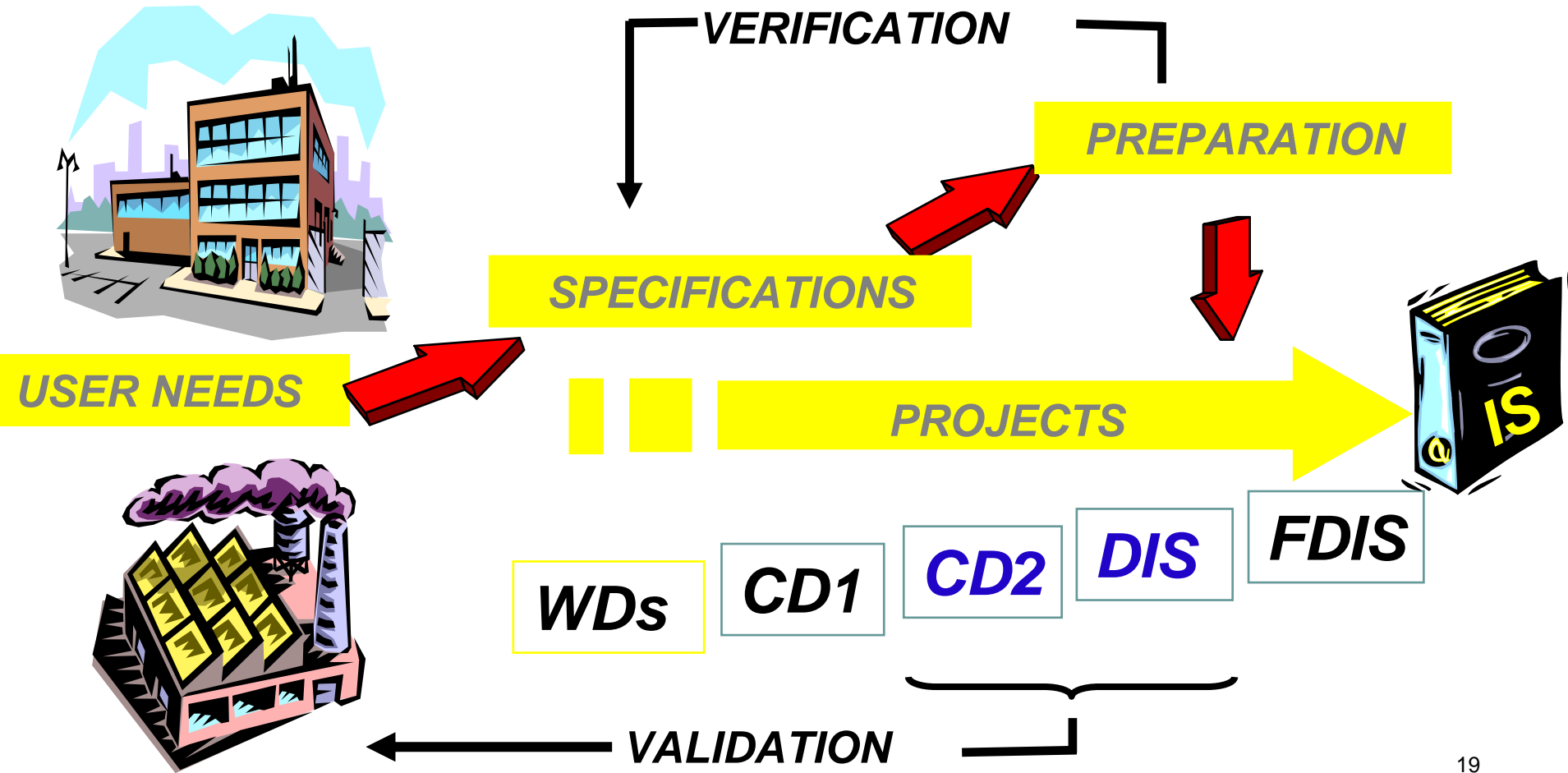

# Next generation of “ISO 9000”

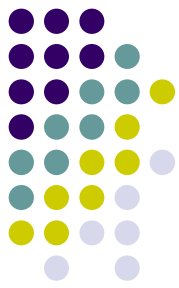

- Summary:
  - ISO 9000:2005 already published – no major changes expected for 2009
  - Current plan is for small changes to ISO 9001 (“amendment”)
  - More significant changes to ISO 9004 (“revision”)
- Design specifications for ISO 9001 and ISO 9004 approved by ISO/TC176/SC2 in Sept 2005.
- Committee Drafts are currently being circulated for comment by ISO/TC176/SC2 members

# ISO 9001:2009

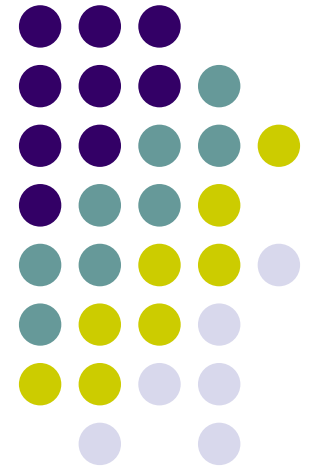

# ISO 9001

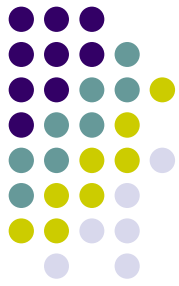

- Main objectives of ISO 9001:2009:
  - to provide greater clarity and ease of use
    - incorporate improvements to address the interpretations and clarifications requested by users through the ISO/TC176 Interpretations Process
  - to improve compatibility with ISO 14001:2004

# What do we mean by “Amendment” to ISO 9001?



- No formal ISO distinction between a “revision” and an “amendment”
- Aim is to emphasize that no MAJOR changes to the requirements are expected for ISO 9001
  - Focus is on changes that improve clarity, translatability, and ease of use; address ambiguities that resulted in requests for interpretations; improve consistency with the ISO 9000 Family, and improve compatibility with ISO 14001:2004,



# Impacts and benefits

- Amendment to ISO 9001 will focus on high benefit / low impact improvements
- Some high benefit / high impact improvements will be saved for the next revision cycle
- Criteria for assessing impact ...

# Key Inputs for the Amendment



- ISO/TC 176 approved interpretations,
- The ISO 9001:2000 Introduction & Support Package set of documents.
- Systematic Reviews conducted on ISO 9001:2000 and ISO 9004:2000
- Web based User Feedback Survey conducted by ISO/TC 176/SC2
- ISO 14001:2004,
- ISO Guide 72:2001, Guidelines for the justification and development of management system standards – Market Justification Study



# Interpretations Process

- 37 Official TC176 Interpretations published on ISO website
  - See [www.tc176.org/](http://www.tc176.org/) for details
- Important source of input for ISO 9001:2009
  - Some interpretation requests indicate need for clarification

# The ISO 9000:2000 Support Package / Guidance documents

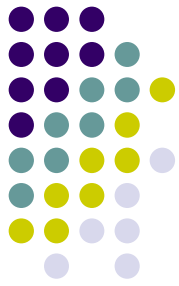

- Documentation requirements
- The process approach
- Application of ISO 9001:2000 (“Permissible Exclusions”)
- Guidance on “Outsourcing”
- Available from [www.iso.org](http://www.iso.org)

# Results of User Survey (2003)

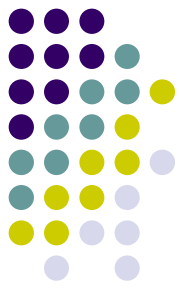

- Responses from 941 users in 63 countries.
- 1477 individual comments
- All four ISO 9001:2000 product categories (Hardware, Software, Processed Materials and Services) well represented.
- Approx 80% of respondents were satisfied with the ISO 9001:2000 standard.

# Survey responses

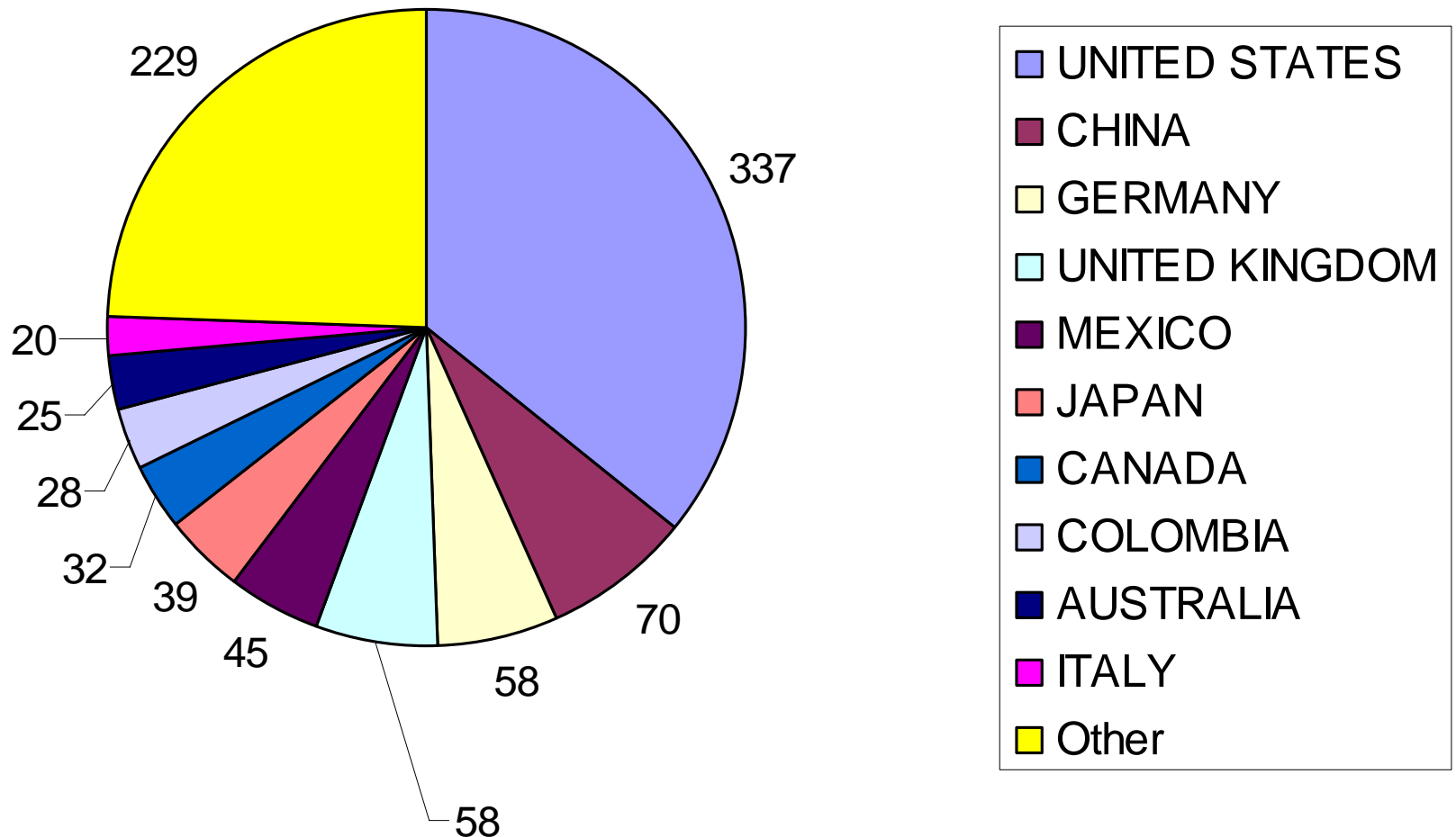

# Size of organization

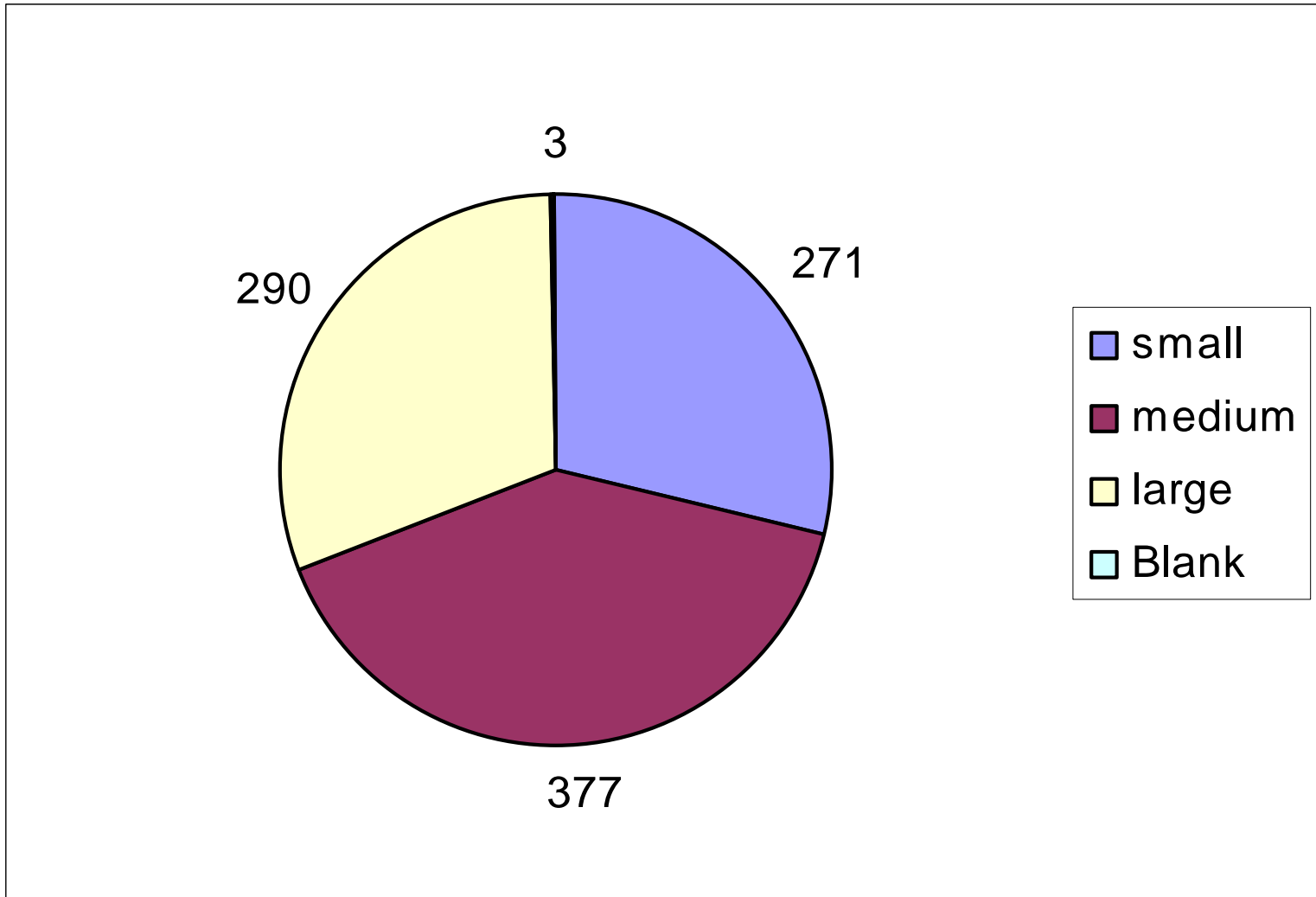

# How long certified?

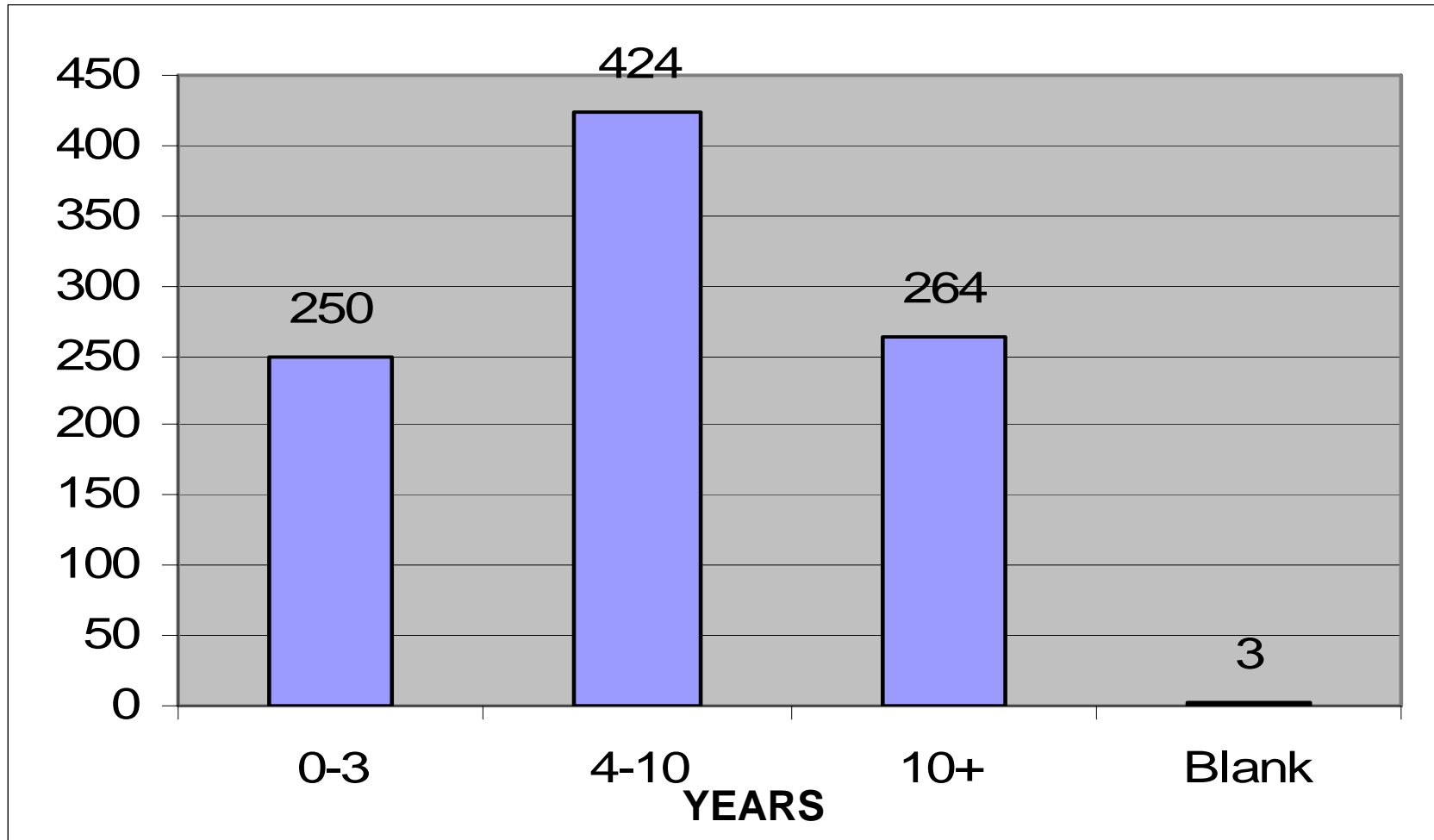

# How well does ISO 9001:2000 meet your needs?

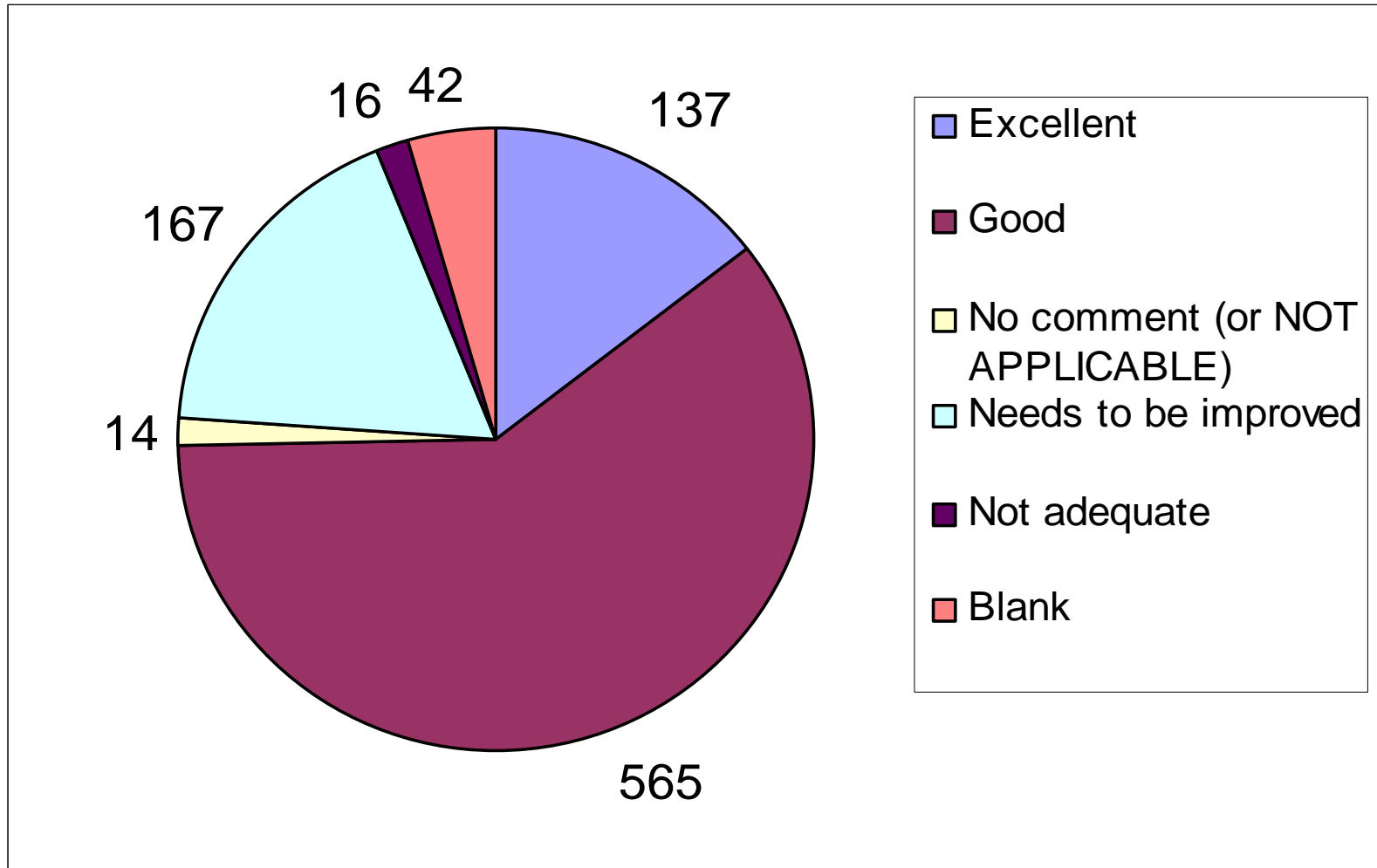
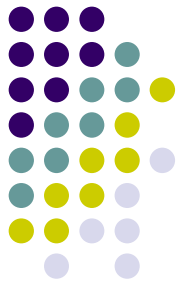

# Are you happy with the process approach?

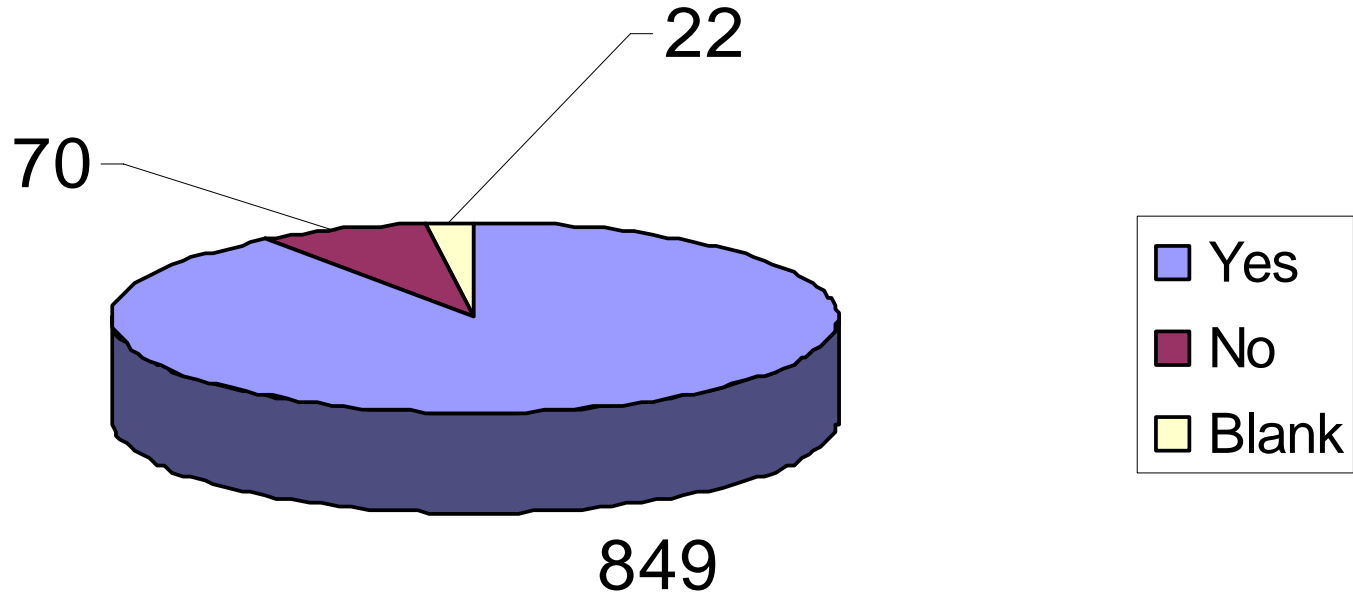
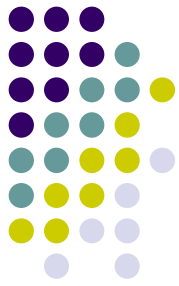

# Most commented clauses / areas of confusion.....

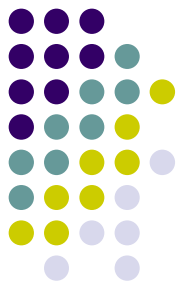

813 (55%) of total 1477 comments related to:

- 4.1 General requirements
- 4.2 Documentation
- 6.2 Human resources
- 7.3 Design and development
- 7.5 Production and Service Provision
- 8.2 Monitoring and Measurement
- 8.5 Improvement

# Key strategies for ISO 9001:2009.....

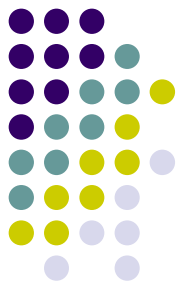

- ISO 9001:2000 Process Approach model will be maintained
- The standard will remain generic and be applicable to all sizes and types of organization operating in any sector.
- Compatibility with ISO 14001:2004 to be maintained and if possible enhanced
- Consistency with the revision of ISO 9004:2000 will be maintained
- Changes will be restricted to limit impact on users

# Key strategies for ISO 9001:2009..... (Continued)

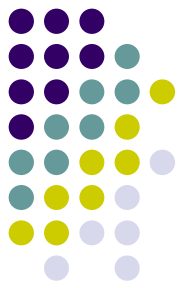

- The ISO 9001:2000 support package will be used to assist the writers to identify issues needing clarification.
- Ambiguities requiring formally produced interpretations will be addressed
- Changes only introduced where there are clear benefits
- Drafts of the amended standard will be subjected to verification against the design specification, and to validation by users

# Maintaining the “Consistent Pair” of QMS standards

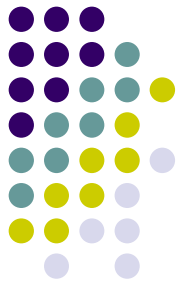

- The ‘consistency’ between the amendment of ISO 9001:2000 and the revision of ISO 9004:2000 means:
  - lack of conflict between the standards,
  - the standards fit well together, but are able to stand alone,
  - harmonized concepts and terminology,
  - easy transition from one standard to the other,
  - the two standards can be readily applied within the same quality management system.
  - each standard will have a structure that best meets the needs of its users

# Compatibility with ISO 14001

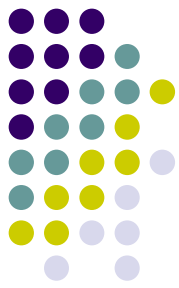

- “Compatibility” means that common elements of the standards can be implemented by organizations in a shared manner, in whole or in part, without unnecessary duplication or the imposition of conflicting requirements.
- When maintaining compatibility with ISO 14001:2004 the following do not necessarily represent potential conflicts:
  - Different text in common elements or terminology
  - Different numbering of the clauses
  - Different models and structure
  - Inclusion of guidance, notes or annexes

# Compatibility with Sector specific and other standards

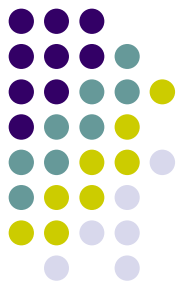

- Sector standards based on ISO 9001:2000
  - Example ISO/TS 16949; TL 9000
- Other management system standards that are based on ISO 9001:2000 and use its structure and text.

# Other decisions already made for ISO 9001:2009 .....



- The current scope, purpose, title and field of application of the standard will be unchanged.
- The 8 Quality Management Principles (as contained in ISO 9000:2005) will be applied, unchanged.

# ISO 9004:2009

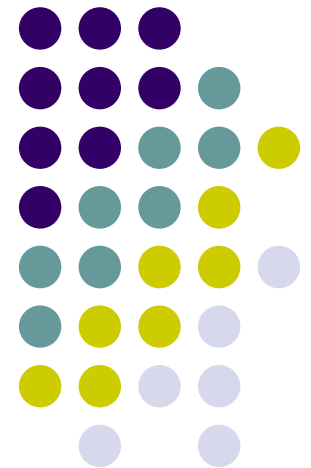

# Purpose of ISO 9004:2009.....

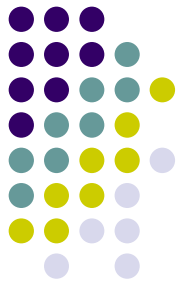

- “To help organizations who are users of ISO 9001 obtain sustained benefit from the implementation of a more broad-based and in-depth quality management system”.

# Objectives for ISO 9004:2009



- Facilitate improvement in users' quality management systems
- Provide guidance to an organization for the creation of a quality management system that:
  - creates value for its customers, via the products it provides
  - creates value for all other interested parties,
  - balances all interested-party viewpoints.
- Provide guidance for managers on leading their organization towards sustainable success.
- Forward compatibility to allow organizations to build on existing quality management systems.

# Target customers for ISO 9004:2009



- First Priority
  - Current users of ISO 9001:
  - Organizations just getting started on ISO 9001
- Second Priority
  - Organizations who are not users of ISO 9001 who want to go farther in QMS implementation than 9001

# ISO 9004:2009 is *not* intended to be:



- An implementation guide to ISO 9001
- A business excellence model
- A set of requirements
- A textbook on Total Quality Management
- A source of untried approaches and methods

# “Guiding Principles” for ISO 9004:2009



- Continue to use the “eight Quality Management Principles”, but also take into account:
  - Ethics /social aspects
  - Mission and Vision of the organization
  - Adaptability / agility (ability to respond to changing opportunities / threats).
  - Management of knowledge.
  - Alignment with other management systems
  - Linking objectives and actions to results.
- Concept of the “Consistent Pair” (ISO 9001 and 9004) to be maintained, but with more flexible criteria for “consistency”

# Schedule (ISO 9001 and 9004)



- 2004 – User survey results received and analyzed; systematic review performed
- 2005 – Design specs approved
- 2006/2008 – Drafting and consensus process
- 2009 – Publication
- 2009/2010 – Transition period for ISO 9001 certification
  - To be defined by ISO and IAF (likely to be 18 months)

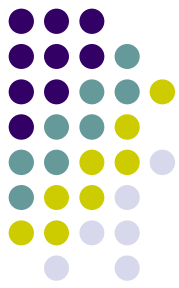

# For further information:

- ISO web site [www.iso.org](http://www.iso.org)
- Your National Standards Body
- ISO Liaison Member web sites
- ISO/TC176/SC2 website
- ISO Management Systems magazine
- ISO Press releases



- Was war Ihnen besonders wichtig?
- Welche weiteren Informationen benötigen Sie?
- Wie ist Ihre Meinung zu den dargestellten Ansätzen?



Vielen Dank für  
Ihre  
Aufmerksamkeit

## ***Deutsche Gesellschaft für Qualität e. V.***

August-Schanz-Str. 21A  
60433 Frankfurt/Main

Olaf Stuka

069 / 9 54 24 -124

os@dgg.de

***www.dgg.de***